

Double function Air Valve

Mod. SFI-SNG

Technical Data

- Single floater design
- Maximum working pressure: PN10/PN16
- Temperature range: +5°C/+45°C
- Suitable for potable water
- Internal and external fusion bonded epoxy coating

Normative Standards

- Design: EN 1074-4
- Flange: EN 1092-2
- Test: EN 12266-1
- Coating: EN 30677

Optional

- Special coating
- Flange drilling ANSI, BS
- PN25 version

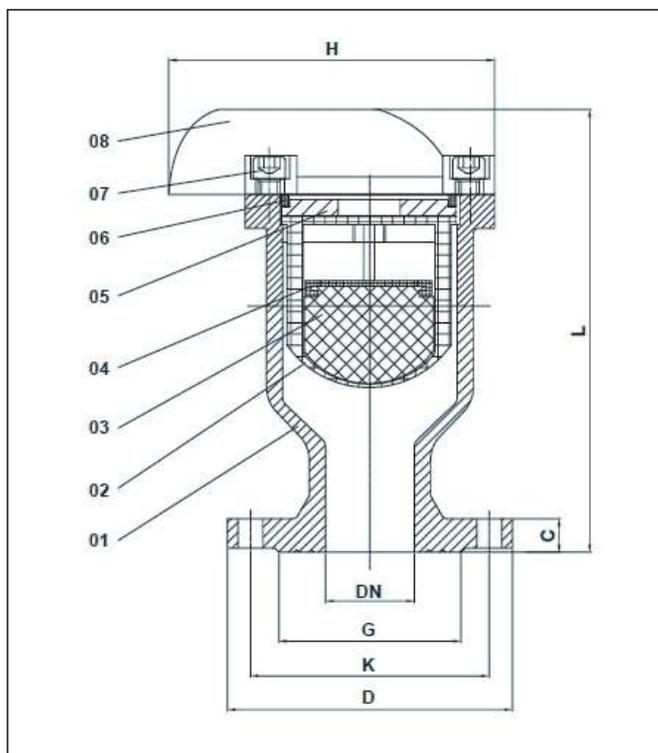

N	Description	Material	Standard
1	Body	EN GJS 500-7	EN 1563
2	Net	PLASTIC	-
3	Floater	PLASTIC	-
4	Gasket	EPDM	EN 681
5	Internal Cover	BRASS	EN 1982
6	Gasket	EPDM	EN 681
7	Bolt	Grade 8.8	-
8	Bonnet	EN GJS 500-7	EN 1563

Dimensions and weights:

DN	D	PN 10			PN 16			L	H	Weight [kg]
		K	n-d	C	K	n-d	C			
50	165	125	4-20	19	125	4-20	19	255	185	11
65	185	145	4-20	19	145	4-20	19	255	185	12
80	200	160	8-20	19	160	8-20	19	255	185	16
100	220	180	8-20	19	180	8-20	19	325	270	23
150	285	240	8-24	19	240	8-24	19	325	270	25