



Quick Relief Valve Mod. IN/IP-SR

Hydraulic Function

The hydraulic valve mod. IN/IP-SR is an automatic security valve that discharge the pressure peak in the network protecting the system against high pressure.

Operation Principle

The valve is installed in order to discharge outside of a pressurized network system and is controlled by a 2 way quick relief control pilot (mod. SR-P). When the pilot senses a too high pressure will open totally the valve discharging the pressure peak.

The pilot, when the pressure level is lower than the setted value, maintains the chamber totally filled and the valve closed. When the sensor of the pilot senses that the pressure is growing over the limit, the valve will open very fast discharging the overpressure. Once the overpressure is discharged the valve will close very slowly in order to not generate a counter water hammer.

The pilot can be adjusted to the desired pressure, within its limit of regulation range. When the upstream pressure is lower than the setted value the 2 way circuit maintains closed the valve. When the upstream pressure starts growing higher than the setted value the valve totally opens.

First Installation

- tighten until the limit the adjustment screw on the pilot.
- check that downstream the valve there is enough empty space that when there is a pressure peak and the valve discharge outside people or goods will not be damaged.
- fill the pipe and pressurize the system, the valve will close and will remain closed.
- increase progressively the pressure up to the value at which the valve have to discharge .
- thighten the adjustment screw until the valve start to open.
- block the adjustment screw using the locking nut.

Adjustment

The pilot adjustment screw allows to adjust the pressure to a value that is within its regulation range (check Technical Characteristics). Tightening the screw clockwise increases the regulated pressure value. Unscrewing the screw counter-clockwise reduces the value of the pressure regulated.

Assembly Scheme

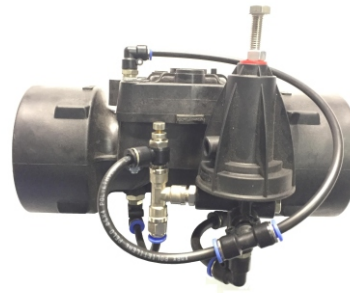
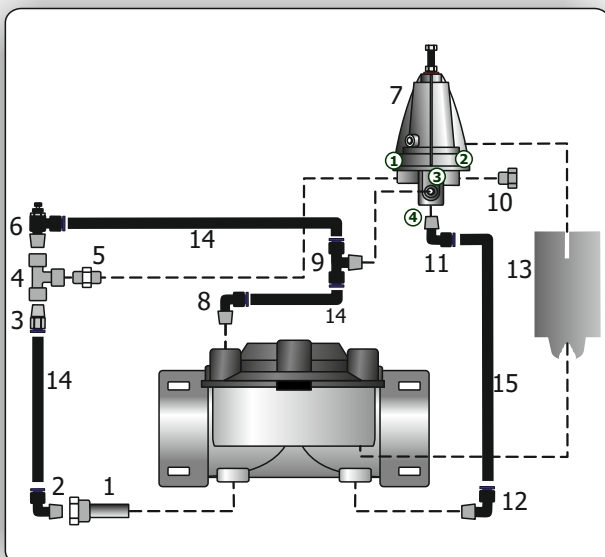

Accessories Features

Quick Relief Pilot SR-P PN10

Lower Body: reinforced nylon
Cover: reinforced nylon

Identification washer

Pressure regulation range:



Red Spring 1,0÷5,5 bar

Black Spring (Standard) 2,0÷9,0 bar

Reccomendations

- do not disassemble the valve or its circuit when the pipe is in pressure.
- do not use with pressures beyond Nominal values.

LEGEND:

- 1 - Filter Ø1/4" M-1/8" F
- 2 - Elbow Ø1/8" M pipe Ø 6 mm
- 3 - Straight Ø1/8" M pipe Ø 6 mm
- 4 - Tee Ø1/8" F-Ø1/8" F-Ø1/8" F
- 5 - Nipple Ø1/8" M-Ø1/8" M
- 6 - Needle Valve Ø1/8" M pipe Ø 6 mm
- 7 - Quick Relief Pilot SR-P
- 8 - Elbow Ø1/4" M pipe Ø 6 mm
- 9 - Tee Ø1/8" M pipe Ø 6 mm
- 10 - Metal plug Ø1/8" M
- 11 - Elbow Ø1/8" M pipe Ø 8 mm
- 12 - Elbow Ø1/4" M pipe Ø 8 mm
- 13 - Pilot stainless steel support
- 14 - Micropipe HDPE Ø 6 mm
- 15 - Micropipe HDPE Ø 8 mm

- ① - Sensor Port
- ② - Blocked
- ③ - Common/Water Inlet
- ④ - Discharge

NOTES:

- fittings and micropipe Ø 8 mm for valves of Ø6" or superior.
- the technical characteristics can change without prior notice.